

SHOULDER

SHOULDER ELECTRONICS LIMITED

SPECIFICATION FOR APPROVAL

NO 编号: _____

CUSTOMER 客 户: _____

PRODUCT 产 品: _____ SAW RESONATOR _____

MODEL NO 型 号: _____ HDR423D TO-39 +-75KHZ _____

PREPARED 编 制: _____ Fengyu _____ CHECKED 审 核: _____ York _____

APPROVED 批 准: _____ Lijiating _____ DATE 日 期: _____ 2007-05-07 _____

CUSTOMER 客户确认意见:

CHECKED 审 核:

APPROVED 批 准:

DATE 日 期:

公司地址: 广东深圳市福田区车公庙泰然工业区 303 栋 5 楼西座
West 5/F, 303 Bldg., Che Gong Miao, Industry Park, Futian
Dist., Shenzhen, Guangdong, China.

Tel: 86-755-82916880 Fax:86-755-82916881

工厂地址: 江苏无锡市滨湖经济技术开发区高运路 115 号

No. 115, Gaoyun road, Binhu Economic&Technology Development
Area, Wuxi, Jiangsu, China

Tel:86-510-5629111 Fax:86-510-5627222

[Website:www.shoulder.cn](http://www.shoulder.cn)

1. SCOPE

This specification shall cover the characteristics of 2-port SAW resonator with used for remote-control security.

2. ELECTRICAL SPECIFICATION

DC Voltage VDC	10V
AC Voltage Vpp	10V50Hz/60Hz
Operation temperature	-20°C to +85°C
Storage temperature	-45°C to +85°C
RF Power Dissipation	0dBm

Electronic Characteristics

Item	Unites	Minimum	Typical	Maximum
Center Frequency	MHz	423.145	423.220	423.295
Insertion Loss	dB		1.5	2.5
Quality Factor Unload Q			11,000	
50 Ω Loaded Q			2,000	
Temperature	Turnover Temperature	°C	39	
Stability	Turnover Frequency	KHz	$f_0 \pm 2.7$	
	Freq.temp.Coefficient	ppm/°C ²	0.032	
Frequency Aging	ppm/yr		< ± 10	
DC. Insulation Resistance	M Ω	1.0		
Motional Resistance R1	Ω		10	26
RF Equivalent				
RLC Model	Motional Inductance L1	μ H	86	
	Motional Capacitance C1	pF	1.56	
Shunt Static Capacitance	pF	1.7	2.0	2.3

3. TEST CIRCUIT

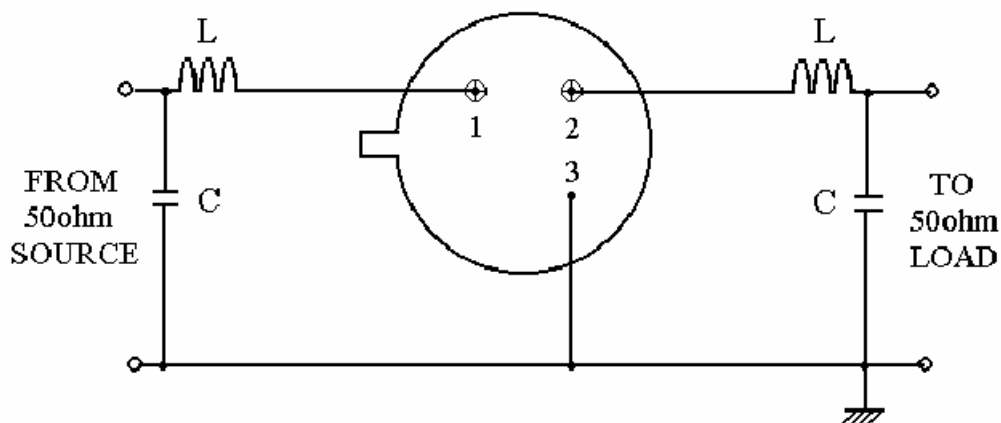

4. DIMENSION

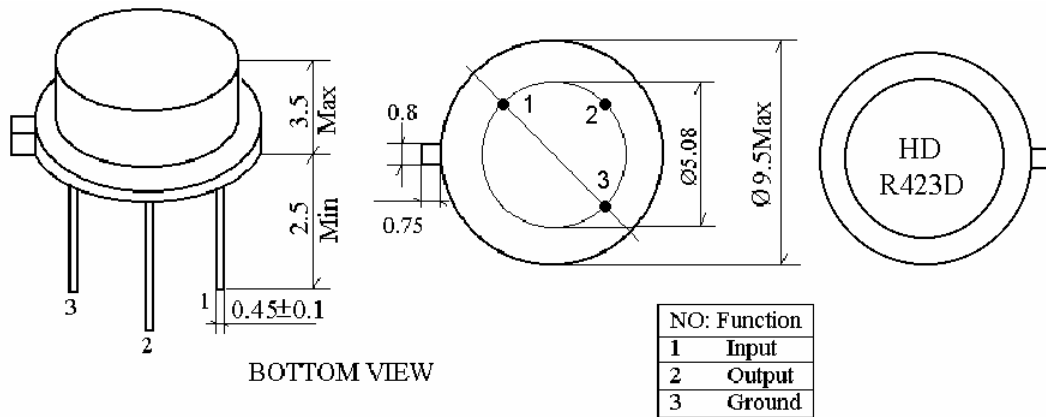

ENVIRONMENTAL CHARACTERISTICS

5-1 High temperature exposure

Subject the device to +85°C for 16 hours. Then release the filter into the room conditions for 24 hours prior to the measurement. It shall fulfill the specifications in table 1.

5-2 Low temperature exposure

Subject the device to -20°C for 16 hours. Then release the device into the room conditions for 24 hours prior to the measurement. It shall fulfill the specifications in table 1.

5-3 Temperature cycling

Subject the device to a low temperature of -40°C for 30 minutes. Following by a high temperature of +80°C for 30 Minutes. Then release the device into the room conditions for 24 hours prior to the measurement. It shall meet the specifications in table 1.

5-4 Resistance to solder heat

Dip the device terminals no closer than 1.5mm into the solder bath at 260°C \pm 10°C for 10 \pm 1 sec. Then release the device into the room conditions for 4 hours. The device shall meet the specifications in table 1.

5-5 Solderability

Subject the device terminals into the solder bath at 245°C \pm 5°C for 5s, More than 95% area of the terminals must be covered with new solder. It shall meet the specifications in table 1.

5-6 Mechanical shock

Drop the device randomly onto the concrete floor from the height of 1m 3 times. the device shall fulfill the specifications in table 1.

5-7 Vibration

Subject the device to the vibration for 1 hour each in x,y and z axes with the amplitude of 1.5 mm at 10 to 55 Hz. The device shall fulfill the specifications in table 1.

5-8 Lead fatigue

5-8-1 Pulling test

Weight along with the direction of lead without an shock 1kg. The device shall satisfy all the initial Characteristics.

5-8-2 Bending test

Lead shall be subject to withstand against 90°C bending with 450g weight in the direction of thickness. This operation shall be done toward both direction. The device shall show no evidence of damage and shall satisfy all the initial electrical characteristics.

6. REMARK

6.1 Static voltage

Static voltage between signal load & ground may cause deterioration & destruction of the component. Please avoid static voltage.

6.2 Ultrasonic cleaning

Ultrasonic vibration may cause deterioration & destruction of the component. Please avoid ultrasonic cleaning

6.3 Soldering

Only leads of component may be soldered. Please avoid soldering another part of component.